

OPUS[®]

THE MULTI-AWARD WINNING
SELF-INFLATING CAMPER



NEW
PRODUCT
LAUNCH

ORX

LIMITLESS OFF-GRID ADVENTURES



SCAN WITH YOUR
SMARTPHONE!

opuscamper.co.uk



The OPUS® ORX delivers an unrivalled off-grid experience. Enhanced overlanding capabilities, a dynamic outside kitchen with a stainless steel 4 burner hob and sink, 80 litres of on-board water storage, built in entertainment system and much more, all included in our most equipped self-inflating camper ever.

SPECIFICATION

DIMENSIONS

Overall length (closed) inc. drawbar	540cm
Overall width	210cm
Internal length (main body section)	282cm
Internal width (main body section)	187cm
Towing height	140cm
Wheels	215/65/R16
Overall length (erected)	640cm
Overall height (erected)	340cm
Interior height (max)	255cm
Bed Size 1	126 x 183 cm
Bed Size 2	126 x 183 cm

WEIGHTS

MIRO (mass in running order)	1400kg
Max tow ball mass (Nose Weight)	110-165kg
MTPLM	1450-1750kg
User payload	50-300kg



INCLUDED AS STANDARD

INTERIOR

- BUILT IN ELECTRIC PUMP FOR INFLATION
- ORX CLUB LOUNGE
- 1 X KING SIZE BED EXTENSION
- 2 X DOUBLE MATTRESSES
- INNER BED TENTS
- STORAGE CUPBOARDS
- FOLDABLE TABLE
- DIMMABLE FLOOR LEVEL LIGHTS
- INTEGRATED ORX SOUND SYSTEM
 - MARINE SPEC STEREO SPEAKERS
 - STEREO WITH BT/USB/CD/FM INPUTS

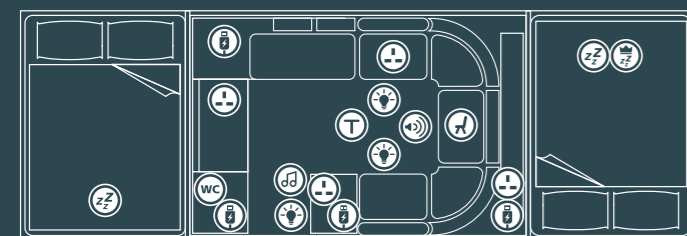

UTILITIES

- BATTERY BOX WITH 13 PIN HOOK UP
- GAS LOCKER (STORAGE FOR 2 BOTTLES)
- INTERNAL 12V, USB & 230V SOCKETS
- EXTERNAL GAS OUTLET & 230V, 12V AND USB SOCKETS
- BUILT-IN 80L (2 X 40L) FRESH WATER STORAGE
- INTEGRATED EXTERNAL SHOWER
- OPUS® UTILITY CENTRE CONTROL PANEL

ROOF CARRYING

- 200KG PAYLOAD FOLDABLE ROOF STORAGE RACK

EXTERIOR

- OPUS® FSG300 AIR TENT WITH OPUV+ ROOF COVER
- KNOTT OFF-ROAD CHASSIS
- ALL-TERRAIN ALLOY WHEELS AND TYRES
- INDEPENDENT SPRING SUSPENSION
- PROTECTIVE STONE CHIP GUARD
- QUICK PITCH CORNER STEADIES & BED SUPPORTS
- ROOF COVER
- 2 X WASTE WATER STORAGE LOCATIONS
- LARGE EXTERNAL STORAGE LOCKER
- 2 HEAVY DUTY SLIDE OUT DRAWERS
- 230V POWER SOCKET
- AUTOMATIC LIGHTS & VENTILATION
- FOLDING ENTRY STEPS
- XL SLIDE OUT STAINLESS STEEL KITCHEN
 - 4 BURNER GAS HOB
 - SINK WITH FOLDING DRYING RACK
 - PREPARATION SURFACE
 - CUTLERY AND ACCESSORY DRAWERS
- EXTERNAL SHOWER FITTING
- FILLING POINTS FOR 2 X 40L FRESH WATER TANKS

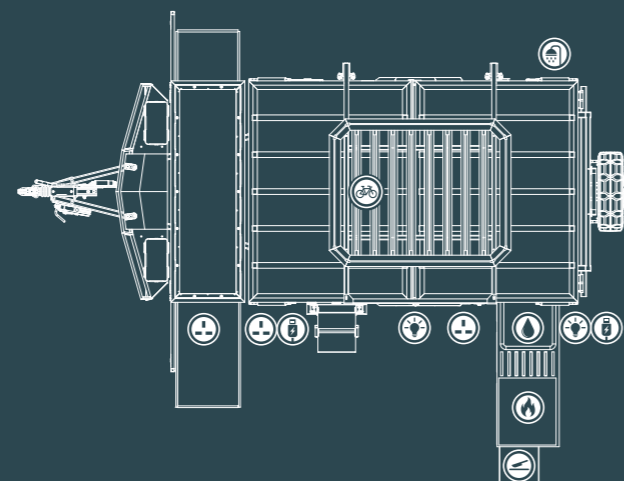

YOUR OPUS ADVENTURE STARTS WITH 4 EASY STEPS!

1 - COLOUR

The OPUS® ORX is available in:

ANTHRACITE GREY

2 - PACKAGE

Choose to configure your own OPUS® or choose a lifestyle package to get loads of optional extras and savings!

The OPUS® ORX pre-order package gives you everything in the standard package and adds 13 optional extras bundled together to save you £3,427 compared to purchasing them individually.

STANDARD PACKAGE
£27,995*

PRE-ORDER PACKAGE
£29,995**

3 - WEIGHT

Choose the weight (MTPLM) of your OPUS®. This will include anything you'd like to store on top or inside the ORX and cannot exceed the maximum towing capacity of your tow vehicle. MTPLM options available from 1450kg - 1750kg in 50kg increments:

4 - FIND YOUR CLOSEST DEALER AND START YOUR OPUS ADVENTURE!

Find your local OPUS® dealer online at:

www.opuscamper.co.uk

OPTION PRICE

STANDARD
PRE-ORDER

INTERIOR	OPTION PRICE	PACKAGE
35L COMPRESSOR FRIDGE/FREEZER	£399	•
230V PORTABLE MICROWAVE	£125	•
ROOM DIVIDER FOR KING SIZE BEDROOM / CHANGING ROOM	£75	•
STANDARD MATTRESS TOPPER UPGRADE	£145 each	
KING SIZE MATTRESS TOPPER UPGRADE	£199	
THERMAL ROOF LINING	£35	
CONDENSATION MATTING	£70 each	
CLOTHES RAIL	£25	
AIR TUBE HANGING STORAGE POCKETS	£25	
SLEEP TIGHT INNER TENT SINGLE	£105 <i>Upgrade for £70</i>	
SLEEP TIGHT INNER TENT PAIR	£210 <i>Upgrade for £140</i>	
LIGHTING + POWER		
DIMMABLE LED LIGHTING - MAIN TENT	£55 each	•
25 METRE MAINS CABLE	£59	•
110AH LEISURE BATTERY	£129	•
100AH LITHIUM BATTERY WITH BLUETOOTH	£695 <i>Pre-order upgrade £566</i>	
126AH LITHIUM BATTERY WITH BLUETOOTH	£849 <i>Pre-order upgrade £720</i>	
EXTERIOR		
ALL-TERRAIN SPARE WHEEL & CARRIER	£549	•
KNOTT® STABILISING HITCH NOT SUITABLE FOR OFF-ROAD USE	£449	
NATO OFF-ROAD HITCH	£349	
QUATTRO® RHODIUM MANUAL ENGAGEMENT MOTOR MOVER	£899	•
QUATTRO® DIAMOND AUTOMATIC ENGAGEMENT MOTOR MOVER	£1,299 <i>Pre-order upgrade £400</i>	
HAND PUMP	£25	•
CONTINUED >>>		

OPUS[®]

ORX

Find your local OPUS[®] dealer
online at
www.opuscamper.co.uk

More questions? Call us on
01473 601200

Head office
Purple Line Limited
Peninsula Business Centre
Wherstead
Suffolk
IP9 2BB, UK

 /opus.folding.camper

 /opuscamper

 /opuscamper

 /opuscamperhq



*Ex works delivery charge.
+To obtain pre-order pricing the ORX Pre Order
Package must be collected before 31/01/25

PCT Patent Pending GB/2017/050391

2024 Purple Line Limited. Pricing effective from
01/09/2024 and correct at time of print.
Purple Line Limited. reserve the right to change
product specification without prior notice. E & OE.

UK2024_ORX

	OPTION PRICE	STANDARD	PRE-ORDER
UTILITIES			
PORTABLE TOILET	£99		•
INTEGRATED BLOWN AIR HEATING (GAS)	£899		
INTEGRATED HOT WATER SYSTEM (DUAL FUEL)	£1,499		
INTEGRATED HOT WATER SYSTEM AND AIR EN-SUITE PACKAGE	£1,995		
SPACE			
COMPLETE AIR AWNING - INCLUDING: MAIN AWNING PAIR OF INNER BED TENTS REMOVABLE GROUND SHEET FRONT SKIRT WITH STORAGE POCKETS	£2,499		•
DIMMABLE LED LIGHTING - AWNING & CANOPY	£55 each		•
AIR SUN CANOPY	£449		
AIR SUN CANOPY STORM BARS	£95 per pair		
PAIR OF SIDE SKIRTS INCLUDING REAR SKIRT	£399		•
AIR WINDBREAK SET - INCLUDING: 2 X LARGE PANEL 2 X SMALL PANEL HAND-PUMP	£375		
AIR WINDBREAK - LARGE PANEL	£175		
AIR GAZEBO	£599		
AIR EN-SUITE & UTILITY TENT	£499		
ROOF CARRYING			
THULE [®] ROOF BAR FEET	£145 per set		
THULE [®] WINGBAR ROOF BARS	£130 per pair		
THULE [®] SLIDEBAR ROOF BARS	£315 per pair		
THULE [®] FREERIDE BIKE CARRIER	£100 each		
THULE [®] PRORIDE BIKE CARRIER	£175 each		
THULE [®] KAYAK CARRIER	£135 each		
SECURITY			
NEMESIS [®] WHEEL CLAMP	£185		•
SARACEN [®] HITCH LOCK	£99		
MOVING INTELLIGENCE TRACER Mi01	£199		